



DT122

Dual digital temperature probe

Accurate temperature control is crucial in any position where living cells are handled. The standard temperature setting of 37 °C reflects the human body's natural condition, providing an ideal environment for most cell types. Utilizing a flat temperature probe with a copper bottom enhances the accuracy of temperature measurements due to its superior thermal conductivity, which is vital for maintaining the integrity and health of the cell cultures. This attention to detail in equipment design significantly contributes to the success of IVF treatments and biological research.

Functions & Technology

Dual temperature probe

The DT122 is a versatile tool, equipped with dual temperature sensors within a single probe, enabling simultaneous measurements at two distinct locations.

NiloChecker 500 expands these capabilities, allowing for the measurement and calibration of up to ten different positions or chambers at once, and precision in various applications.



Specifications

Sensor type	2 x Digital temperature sensors
Measure range & accuracy	-20 - 50 °C/0,03 °C accuracy possible.
Display resolution and update	0,01 °C, one update per second
T90 (min:sec)	1:45
Compliance	ISO/EN61010-1 - RoHS
	Medical grade sensor - ISO 80601-2-56
Operating conditions	0 - 50 °C/5 - 95% RH
Cable length	1,7 m (including 0,5 m flat cable)
Materials	Housing: ABS, Copper.
	Cable: TPE (Flat part), PVC (Round part)
IP Class	IP50
Calibration	Delivered with factory calibration certificate. Accuracy ±0,1 °C Can be calibrated in accordance with ISO/IEC 17025. Calibration requires adaptor. Part no: 115s001.

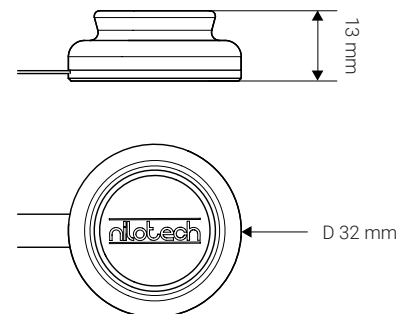

Ordering info

Part no: 122s001 - DT122 Dual Digital Temperature Probe
(Delivered with factory calibration certificate).
Part no: 800s003 - Accredited calibration of 2 temperature sensors.