

DH140 Digital Humidity Probe

Nilotech DH140 Humidity and Temperature Probe is a robust and cost-effective humidity transmitter with high accuracy and good stability. DH140 is suitable for incubators, laboratories, greenhouses and fermentation devices.

Functions & Technology

Robust design

The stainless steel body of DH140 is classified as IP65, making it ideal for rough conditions. DH140 has high chemical tolerance thanks to the digital sensor.

DH140 is connected via a thin flexible cable so it can be positioned inside box- or desk-type incubators without affecting the environment. The magnetic probe holder 140sp002 makes it convenient to install the sensor in the environment. A strong magnet stays firmly attached to steel structures. Alternatively, Ø3.5 mm holes can be used for screw fastening.



Specifications

Sensor type	Capacitive type
Measure range /accuracy	0 - 80% RH, ±1.5%, 0 - 60 °C 80 - 100% RH, ±2%, 0 - 80 °C 20 - 50 °C, ±0.1 °C
Stability	±0,25% RH over 1 year
Display resolution and update	0,1% RH, one update per second
T90 (min:sec)	0:26s
Compliance	ISO/EN61010-1 • EN 61326-1 • RoHS • CE with NiloChecker 500
Operating conditions	0 - 50 °C/5 - 95% RH
Cable length/materials	0,5 m TPE (flat part), 1,2 m PVC (round part) and ABS (junction box)
Sensor Materials	Stainless steel (housing and grid)
IP Class	IP65
Calibration	Delivered with factory calibration certificate Accuracy ±1,5% RH in the range 0 - 80% RH, 0 - 60°C DH140 can be calibrated in accordance with ISO/IEC 17025 Calibration requires an adaptor. Part no: 115s001

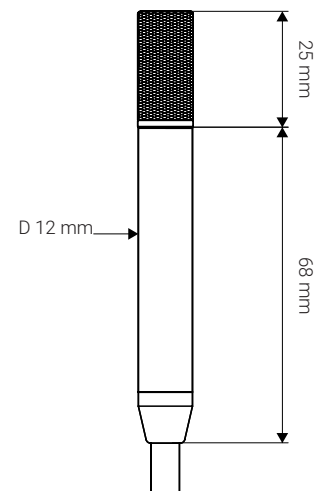

Ordering info

Part no: 140s001 - DH140 Digital Humidity Probe
Part no: 140sp002 - Magnetic Probe Holder for DH140
Part no: 800s016 - Factory R.H. calibration of DH140