



PT123

2,5 x 100 mm stainless steel PT100

The PT123 represents an important advancement in temperature sensing technology. Its stainless steel encapsulated PT100 sensor ensures high accuracy and stability, making it ideal for precision measurements. The immersible tip allows for precise measurements in test tubes, waterbaths and other containers. Quick response time enables real-time monitoring and control.

Functions & Technology

Ideal temperature probe for liquids

The industry standard PT-100 sensor is precise and stable over a wide temperature range. The Nilotech PT123 measures between -50 °C to 100 °C.

PT123 is particularly useful for controlling liquids in water baths, test tubes, and other fluid containers.

The probe can be inserted into any opening larger than 2,5 mm diameter such as sideports on incubators.



Specifications

Sensor type	Analog PT-100 temperature sensor (3 wire)
Measure range & accuracy	-50 - 100 °C, 0,03 °C accuracy possible
Display resolution and update	0,01 °C, one update per second
T90 (min:sec)	0:45
Compliance	ISO/EN61010-1 • RoHS • CE with NiloChecker 500
Operating conditions	0 - 50 °C/5 - 95% RH
Cable length	2 m with option for customisations
Materials	Tip: Stainless steel - Cable: PVC
IP Class	IP50
Calibration	Delivered with factory calibration certificate. Accuracy ± 0,1 °C in the range 0 - 100 °C PT123 can be calibrated in accordance with ISO/IEC 17025 Calibration requires an adaptor. Part no: 115s001

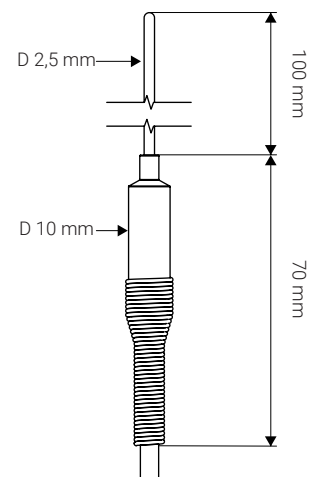

Ordering info

Part no: 120s003 - 2,5 x 100 mm stainless steel PT100
Part no: 115s001 - Single probe calibration adaptor
Part no: 800s012/800s013 AC - Accredited calibration of 1 temperature sensor
Part no: 800s012 - Factory calibration of PT probe in 3 points

Nilotech ApS

Knudstrupvej 14 - DK-4270 Hoeng, Denmark
+45 30 32 32 96 - contact@nilotech.eu - www.nilotech.eu