



DLT145

Digital Laser Tachometer Probe

Centrifuges deliver preparative separation technology, that decides purity and concentration of crucial components used in the laboratory. Keeping your centrifuges in good condition is therefore very important.

Application & Technology

The DLT145 - Digital Laser Tachometer Probe is designed for use with the NiloChecker to measure revolutions per minute (RPM) typically in centrifuges used in the biomedical, chemical, environmental or other analytical laboratories.

The probe utilises state of the art optical detection for measuring speed, using our proprietary hard- and firmware and has the same overall design as all other NiloProbes.

- Head Ø (inner/outer) = Centrifuge (size) range inner 34 mm outer 40 mm

- Receiver: optodiode with front lens to ensure high sensitivity and resistance against external disturbance

- Delivered with reflective tape to mount on one of the centrifuge arms to give well defined reflection

- Housing: softly rounded housing for excellent grip

It's compatibility and ease of use makes it attractive to the service engineer focusing on above mentioned laboratories.



Specifications

Light emission	Red Laser, wavelength 650 nm
Sensor type	Optodiode with front lens
Measure range	Distance up to 100 cm (0 – 40°) Rotations: 10-12.000 RPM 1 RPM, one update per sec.
Display resolution and update	
Compliance	CE with NiloChecker 500 • RoHs
Operating conditions	0 - 40 °C/5 - 85% RH
Cable length	0,5 m
Materials	Cable: PVC coated Housing: Nylon, Polycarbonate (PC)
IP Class	IP50
Calibration	Delivered with traceable factory calibration certificate Can be calibrated in accordance with ISO/IEC 17025 Calibration requires adaptor. Part no: 115s001

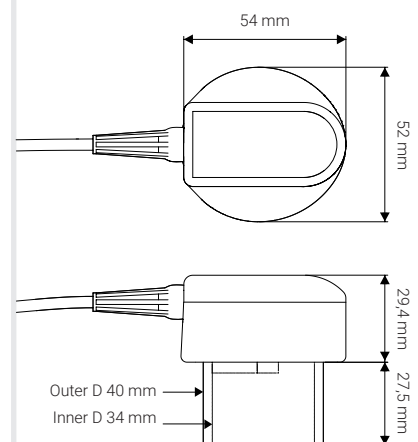

Ordering info

Part no: 145s001 - DLT145 Digital Laser Tachometer Probe - Delivered with factory calibration

Nilotech ApS

Knudstrupvej 14 - DK-4270 Hoeng, Denmark
+45 35 95 32 96 - contact@nilotech.eu - www.nilotech.eu

Document

145d001_03/2026