

nilotech



Nilotech Product Range

QC and monitoring equipment
for specialised labs

Version: 06/2026



Save Precious Time on Quality and Process Control

"When I use my NiloChecker, it is easy and fast to control gas and temperature in incubators. I simultaneously measure both parameters and quickly move to another incubator; the unit even saves all measurements. I always bring the NiloChecker into our various laboratories - it's easy to carry around and super accurate.

A true all-in-one device."

Kirsten Simonsen, MSc

Laboratory Manager, Senior Embryologist
Maigaard Fertilitetsklinik



Reliable and Easy to Use

NiloChecker was the first device of its kind available in our market, and for us, it has proven to be a reliable tool for measuring all key parameters that ensure the stability of the culture system in our IVF laboratory. We purchased all available probes at that time, and I am now looking forward to testing the new ones as well.

One of the greatest advantages for us is that the device does not require calibration while still providing precise and reproducible measurements. Initially, we performed multiple comparisons with other devices, but due to its stability, fast measurements, and consistent results, NiloChecker quickly became our primary tool in daily practice. It saves valuable time because different parameters can be measured simultaneously – for example, temperature and gas levels in one incubator chamber, while measuring temperature in another chamber or on a heated surface.

The probes have sufficiently long cables, allowing measurements to be performed in multiple locations at the same time. This enables embryologists to carry out several checks simultaneously, saving time while minimizing disturbance to sensitive culture conditions inside incubators.

I especially appreciate that Nilotech follows the real demands of IVF laboratory workflow and continuously develops new probes, such as in-dish measurement solutions. They truly understand what matters most to an embryologist – peace of mind and confidence in culture conditions during everyday work.

Mirka Đorđević

Senior Clinical Embryologist
B.B: Clinic, Veljevo



Faster Accurate Services

The adoption of Nilotech by our technical team represented a significant advancement in the quality and reliability of the services our company provides to clients. With Nilotech and its dual probes, we were able to significantly reduce the time required for incubator calibration, making our processes more efficient and enabling us to deliver faster and more accurate services. The variety of available probes allows us to perform a complete cycle of analysis and calibration of equipment used in an assisted human reproduction laboratory without the need to use other measuring instruments, centralizing all activities on a single reliable platform.

In addition, its hundredth-degree resolution increases the metrological reliability of the results and reduces the contribution of resolution to the overall measurement uncertainty. Certificates issued with more refined measurements convey greater technical robustness, credibility, and alignment with good calibration practices and regulatory requirements.

Another important advantage is the technical support provided by the manufacturer, which is always fast and precise. We have access to all the documentation and technical materials necessary to perform repairs with quality, safety, and traceability. Working in the field with Nilotech also represents, in the eyes of our clients, a clear demonstration of our company's commitment to quality, metrological reliability, and the use of the best technologies available on the market.

Fernando Tichauer

Service Manager
Spectrun Bio Engenharia Médica Hospitalar

NiloChecker 500 WiFi

One reference instrument - many applications

As a gold standard within Quality Assurance and Quality Control, The NiloChecker supports measurement of eight different modalities in the IVF laboratory: Temperature, Humidity, CO₂/O₂ Concentrations, Pressure and Flow, Air Flow and RPM – with new probes continuously being launched. The NiloChecker is available in two configurations. The standard version is a preferred all-in-one device for spot check and calibration, used by both laboratory personnel and service engineers. The monitoring version triggers alarms when defined settings exceeds thresholds. It automatically transfers data from equipment to the cloud for storage and documentation, providing a more strategic approach to overall operations of your laboratory.

Application & Technology

Online monitoring

The NiloChecker will together with the NiloCloud ensure constant monitoring of and alarms from the equipment in your lab.

Time saving

Save time on process and quality control. Perform up to 10 simultaneous measurements. For instance, check your incubator for CO₂, O₂, and temperature at the same time.

Easy as 1-2-3

A large touch screen with intuitive software guides you through the measurement. It helps you to perform measurements in accordance with international standards and equipment manufacturers.

Integrated documentation

The Add-to-table function helps you to process and organise data from many measurements.

Long battery life

Just bring the NiloChecker around. The high capacity battery ensures hours of measurement time between charging.

No need for calibration

The instrument is fully digital and will never need calibration. The instrument stays in the lab and measurement probes can be controlled and calibrated separately.

Integrated functions

Graph function: Important tool to track any measurement. Instant measuring: Instrument starts to measure once a probe is connected. Timer function: Start/Stop allows to measure in a predefined time. Calculations: Max, Min, Average, Moving average, Deviation from average. Easy to collect data from multiple probes.

Specifications

Measuring range/accuracy	Depends on connected probe
Display and Touch	7" - 800 x 480 pixel - Capacitive touch - Adjustable brightness
Data storage and export	Internal memory - Export data in csv-format to PC via USB
Compliance	ISO/EN 61010:2010 • IEC 60950-1:2005/ • AMD2:2013 • CE
Operating conditions	0-50 °C - 5-95% RH, IP50
Power supply	12 V/30 W - Wall plug adaptor - 100-240 V
Connectors	5 Pcs - Stainless steel with lock and quick release
Battery time	6-8 hours, depending on use - Battery level displayed in %
Charging Time	Less than 3 hours

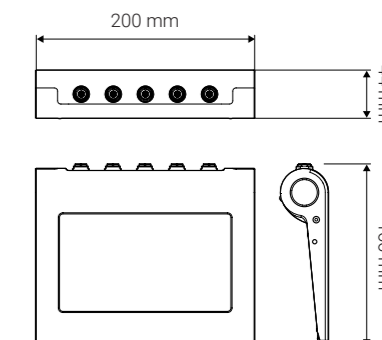

Ordering info

Part no: 111s001 - NiloChecker 500
Part no: 111s002 - NiloChecker 500 WiFi

Nilotech ApS

Knudstrupvej 14 - DK-4270 Hoeng, Denmark
 +45 35 95 32 96 - contact@nilotech.eu - www.nilotech.eu



NiloCloud

A scalable, secure, and seamless solution



NiloCloud

Designed to ease data logging and storage, the NiloCloud offers a unique insight in your operations at all levels. From service departments scheduling maintenance and calibration, creating statistics, and engaging into a meaningful dialogue with the customers, to clinics getting overview of production performance and contract holders being empowered to perform strategic decision making. All in your time and where you decide to do it. Sharing and engaging with colleagues over time and geography the NiloCloud is value creation beyond expectation and perhaps desire.

Application & Technology

Reduce your workload

Automatic collection and storing of data for purposes of quality control and assurance, certification, audit, and long-term performance monitoring provides flexibility in prioritising your tasks.

Secure your data

All data collected from every piece of equipment connected to a NiloChecker is securely stored in the NiloCloud providing complete traceability and documentation.

Get notified

Get notifications at your convenience. Set your preferred limits and schedules and get notifications at your convenience by e-mail or text.

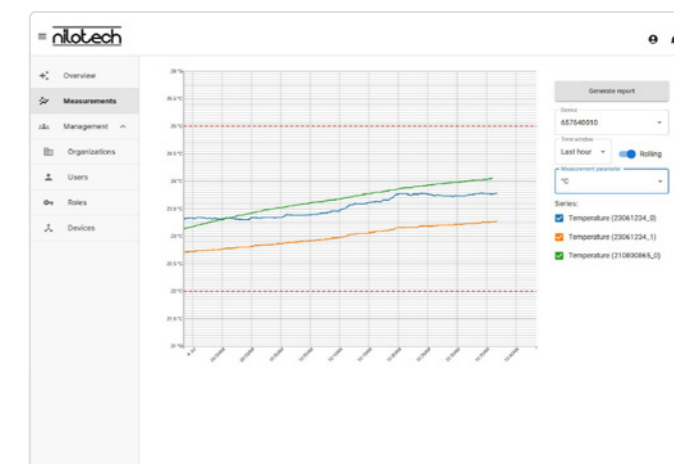

Data Collection

The NiloChecker collects data directly from the source in your laboratory. This automation frees up time for you to focus on your artisan lab work.

Consolidated data allows you to check all parameters from all connected equipment simultaneously from one display.



Workstation

Monitor, analyse and collaborate. From your workstation you can monitor equipment performance in real time and get notified, when set limits are exceeded or discrete procedural steps have finished. You can analyse data from different sources and compare performance, in your own time and from everywhere. You can collaborate with colleagues and peers long-distance across continents and time-zones.

Specifications

NiloCloud	
Connection:	Via local WiFi or LAN/GSM via NiloRouter
Computer requirements (minimum):	Intel® i3, 4 Gb RAM
Cloud Storage Capacity:	Unlimited one year storage
Export format:	*.csv
UPS for NiloRouter	
Input Voltage	9-30 VDC
Output Voltage (battery mode)	12 VDC
Max Output (W/A)	22W/1,8 Ampere
Battery Capacity	2600mAh / 17Wh
Operating Time	1,5 - 4 hours

NiloRouter	
Dimensions (w/o antennas)	(114.5 x 93.6 x 32) mm
Weight	360 g
Interface	Input WiFi, Output LAN or GSM
Networking Interface	(2) GbE RJ45 ports, LTE Category 4 radio WiFi 4.
Max Network Speed	150/50 Mbps (Down/Up)
WiFi Standard	802.11 b/g/n, WiFi 2.4GHz
Ambient operating temperature	-40 °C - 70 °C
Ambient operating humidity	5% to 95% noncondensing
Mounting	DIN rail/wall/pole mount (Included)



Ordering info

- Part no: 500s001** - NiloCloud Quarterly License
- Part no: 500s002** - Text service for NiloCloud
- Part no: 500s003** - NiloRouter Mobile Industrial Router
- Part no: 500s004** - UPS for NiloRouter













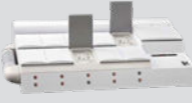
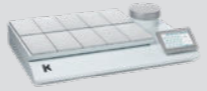

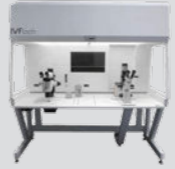
Nilotech ApS

Knudstrupvej 14 - DK-4270 Hoeng, Denmark
+45 35 95 32 96 - contact@nilotech.eu - www.nilotech.eu

Probe Compatibility Table













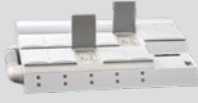



The below table show the compatibility of NiloChecker probes with specific equipment brands and models. Nilotech has performed extensive validation of our solution together with equipment manufactures and/or end users. Correct use of equipment is imperative for correct results, and Nilotech encourages all users to contact us with questions and requests for training.

Target	Box-type Incubator	Cook Minc	ESCO MIRI/TL	K-Systems G185	K-Systems G210	Origio/Planer BT37	Vitrolife EmbryoScope/ EmbryoScope+	IVF Workstation	ICSI Station	Warming Blocks/ Heaters	Cryogenic Applications
Nilotech probe											
Temperature Measurements											
 DT112/-122 Page 11	Shelf temperature	Bottom temperature in chamber						Surface temperature heated table top			
 DT123/-124 Page 13	Temperature inside dish or test tube	Temperature inside dish in chamber						Temperature on heated stage or inside dish	Temperature in test tube		
 DT121 Page 15		Top and bottom temperature in chamber				Top and bottom temperature in chamber					
 PT120 Page 16							Chamber temperature	Temperature on heated stage	Airstream temperature on heated stage		
 PT123 Page 17	Air temperature or temperature in test tube						Chamber temperature in side-port		Temperature in test tube		Temperature in test tube
 PT125 Page 18	Air temperature or temperature in test tube						Chamber temperature in side-port		Temperature in test tube		Temperature in test tube Temperature in cryogenic tank

Probe Compatibility Table



Target	Box-type Incubator	Cook Minc	ESCO MIRI/TL	K-Systems G185	K-Systems G210	Origio/Planer BT37	Vitrolife EmbryoScope/ EmbryoScope+	IVF Workstation	Centrifuge
Nilotech probe									
Gas Measurements									
 DG112 Page 19	CO ₂ and O ₂ inside chamber		CO ₂ and O ₂ inside chamber						
 DG122 Page 20		CO ₂ and O ₂ output from filter	CO ₂ and O ₂ via chamber sample port			CO ₂ and O ₂ output from filter			
 DG126 Page 21	CO ₂ and O ₂ via chamber sample port		CO ₂ and O ₂ via chamber sample port	CO ₂ and O ₂ via sample port	CO ₂ and O ₂ via sample port in chamber lid		CO ₂ and O ₂ via sample port		
 DMF119 Page 22			Pressure and flow measurement					Pressure and flow measurement	
Other Measurements									
 DLV119 Page 23								Laminar airflow measurements and calculations	
 DH140 Page 24	Humidity inside incubator chamber					Humidity inside incubator chamber		Environmental humidity or humidity inside workstation	
 DLT145 Page 25									Measure RPM in rotational devices



DT112/-122
Digital Temperature Probe

Maintaining the correct temperature within incubators is indeed vital for cell viability and development. Typically, incubators are set to 37 °C to mimic the body's conditions and promote optimal cell growth. The use of a flat temperature probe is an excellent method to monitor these conditions accurately. The copper bottom of the probe is a deliberate design feature, ensuring efficient thermal contact with various surfaces, which is essential for reliable temperature readings and, consequently, for the health of the cell cultures.

This probe is available as both single and dual sensor head.

Application & Technology

Temperature probe

This unique surface-temperature probe is ideal for controlling and calibrating incubators and actively heated surfaces.

The design of these sensors, featuring a conductive copper base and an insulating top, ensures maximum thermal contact and accuracy. Moreover, the factory calibration of each sensor, along with the option for a third-party accredited calibration certificate, guarantees reliability.

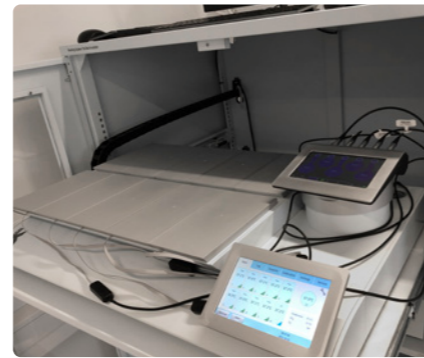
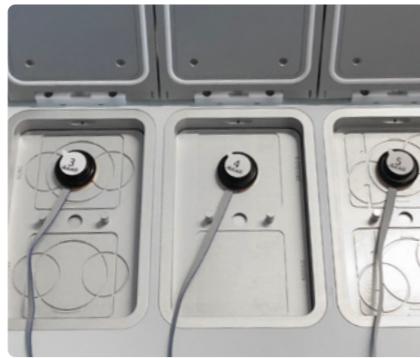

Specifications

Sensor type	Digital temperature sensor
Compatible instruments	NiloChecker 500 and NiloChecker 500 WiFi
Measuring range/accuracy	(-20 to 50) °C / 0,03 °C accuracy possible
Display resolution and update	0,01 °C, one update per second
T90 (min:sec)	1:45
Compliance	ISO/EN61010-1 • RoHS • CE with NiloChecker 500 Medical grade sensor - ISO 80601-2-56
Operating conditions	(0 to 50) °C / (5 to 95)% RH
Cable length	1,7 m (including 0,5 m flat cable)
Materials	Housing: ABS, Copper Cable: TPE (Flat part), PVC (Round part)
IP Class	IP50
Calibration	Delivered with factory calibration certificate. Accuracy ±0,1 °C Can be calibrated in accordance with ISO/IEC 17025 Calibration requires adaptor. Part no: 115s001

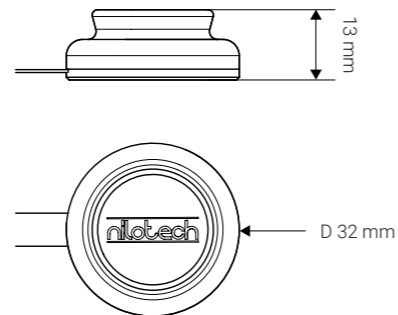

Weight: N/A



Ordering info

- Part no: 112s001** - DT112 Digital Temperature Probe (Delivered with factory calibration certificate)
- Part no: 122s001** - DT122 Dual Digital Temperature Probe (Delivered with factory calibration certificate)
- Part no: 800s010** - Factory calibration of DT probe in 2 points
- Part no: 800s011AC** - Accredited calibration of DT probe in 2 points

Nilotech ApS

Knudstrupvej 14 - DK-4270 Hoeng, Denmark
+45 35 95 32 96 - contact@nilotech.eu - www.nilotech.eu

Document

112d001_06/2026

Available as dual sensor probe

DT123 / DT124

Digital Dish-Temperature Probe

The DT123 Digital Dish-Temperature Probe is a state-of-the-art instrument designed for precision and ease of use in laboratory settings. Its 200 mm flat flexible wire and small sensor allow for accurate temperature measurements in narrow spaces with minimal disturbance of the environment. This sensor is particularly well suited for applications where maintaining the correct temperature is vital for cell viability such as inside dishes.

This probe is available both as single and dual sensor head.

Application & Technology

Dedicated temperature sensor for dishes and tubes

DT123 is ideal for controlling and calibrating heated stages and other sensitive heating devices. The probe can be placed on any surface, such as metal, glass, plastic etc.

We have made it possible to connect 5 different probes to one NiloChecker. Controlling and calibrating your lab equipment has never been faster or easier.

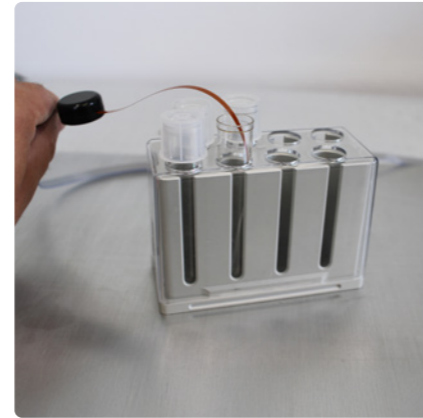
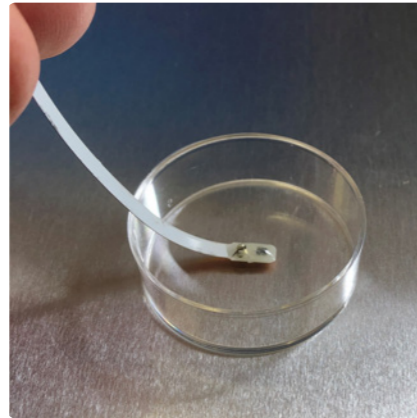

Specifications

Sensor type	Digital Temperature sensor
Compatible instruments	NiloChecker 500 and NiloChecker 500 WiFi
Measuring range/accuracy	(-20 to 50) °C / 0,03 °C accuracy possible
Display resolution and update	0,01 °C, one update per second
T90 (min:sec)	0:45
Compliance	ISO/EN61010-1 • RoHS • CE with NiloChecker 500 Medical grade sensor - ISO 80601-2-56 and ASTM E1112
Operating conditions	(0 to 50) °C / (5 to 95)% RH
Cable length	1,7 m (including 0,5 m flat cable)
Materials	Flexible FR-4, Epoxy Cable: TPE (Flat part), PVC (Round part)
IP Class	IP50
Calibration	Delivered with factory calibration certificate. Accuracy ± 0,1 °C Can be calibrated in accordance with ISO/IEC 17025 Calibration requires adaptor. Part no: 115s001

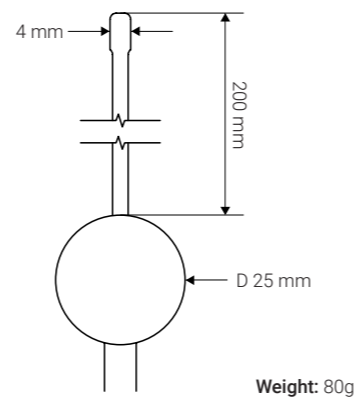

Ordering info

- Part no: 123s001** - DT123 Digital Dish Temperature Probe - Delivered with factory calibration certificate
- Part no: 124s001** - DT124 Dual Digital Dish-Temperature Probe - Delivered with factory calibration certificate
- Part no: 800s011AC** - Accredited calibration of DT probe in 2 points
- Part no: 800s010** - Factory calibration of DT probe in 2 points

Dual temperature probe for dishes, temperature controlling devices, and tubes

The DT124 - Dual Digital Dish-Temperature Probe is particularly ideal for measuring and controlling temperature in dishes and tubes. The sensors can be placed directly on various surfaces such as metal, glass, plastic etc.

You can connect up to five probes to a NiloChecker and measure and calibrate up to ten different positions or chambers at once. This saves you time and ensures reliable performance of critical equipment in your laboratory.

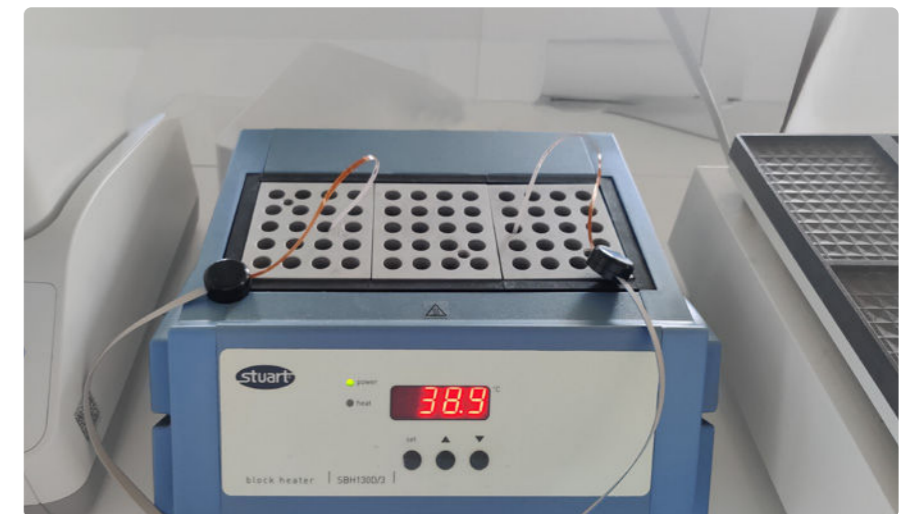

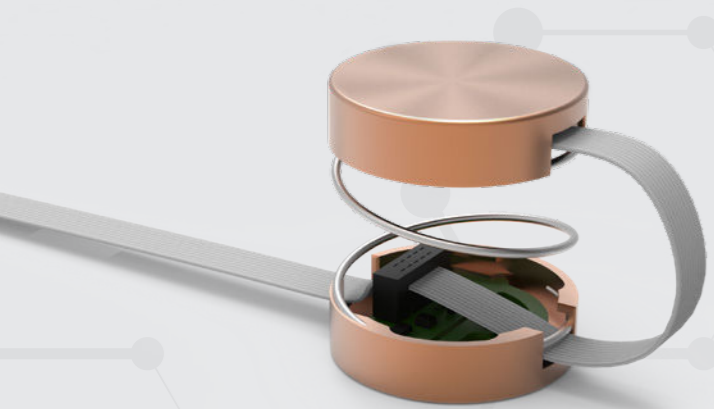

**DT121
Up-Down Digital Temperature Probe**

The DT121 Up-Down Digital Temperature Probe represents a significant advancement in precise temperature control of cell culture incubators. Its innovative design with a copper top and bottom, connected by a spring, ensures optimal thermal contact with both the chamber floor and lid. This dual-measurement capability allows for simultaneous monitoring of two critical points with a single device, streamlining the process and ensuring the integrity of the cell environment.

Application & Technology

Dual measurements

Our unique Up-Down probe is ideal for controlling and calibrating desktop incubators through its 2 digital temperature sensors.

Flexible design

The probe can be placed on an incubator chamber floor, while the spring ensures good contact between upper sensor and lid.

Ease of use

We have made it possible for you to connect up to 5 different probes in one NiloChecker. Controlling and calibrating desktop incubators has never been faster or easier.



Specifications

Sensor type	2 x Digital temperature sensors
Compatible instruments	NiloChecker 500 and NiloChecker 500 WiFi
Measuring range/accuracy	(-25 to 50) °C / 0,03 °C accuracy possible
Display resolution and update	0,01 °C, one update per second
T90 (min:sec)	1:45
Compliance	ISO/EN61010-1 • RoHS • CE with NiloChecker 500 Medical grade sensor - ISO 80601-2-56
Operating conditions	(0 to 50) °C / (5 to 95)% RH
Cable length	1,7 m (including 0,5 m flat cable)
Materials	Housing: Copper Cable: TPE (Flat part), PVC (Round part)
IP Class	IP50
Calibration	Delivered with factory calibration certificate. Accuracy ±0,1 °C Can be calibrated in accordance with ISO/IEC 17025 Calibration requires adaptor. Part no: 115s001

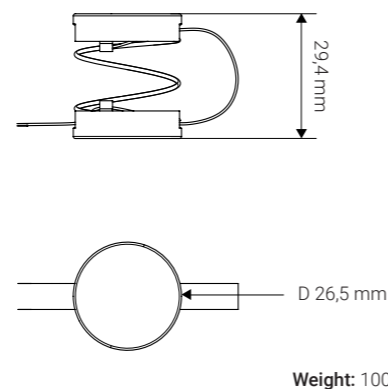

Ordering info

Part no: 121s001 - DT121 Up-Down Digital Temperature Probe (Delivered with factory calibration certificate)
Part no: 800s010/800s011AC - Accredited calibration of DT probe in 2 points
Part no: 800s010 - Factory calibration of DT probe in 2 points

Nilotech ApS

Knudstrupvej 14 - DK-4270 Hoeng, Denmark
+45 35 95 32 96 - contact@nilotech.eu - www.nilotech.eu

Document

121d001_06/2026



**PT120
Platinum 1 mm Flexible Temperature probe**

The PT120 represents a significant advancement in temperature sensing technology. Its platinum construction ensures high accuracy and stability, making it ideal for precision measurement needs. The compact design allows for easy integration into a variety of systems without disturbance, and the quick response time enables real-time monitoring and control.

Application & Technology

Ideal temperature probe for narrow openings down to 1 mm in diameter

This superior quality PT-100 sensor is precise and stable over a wide temperature range.

PT120 is also particularly useful for controlling heated stages inside dishes and other sensitive heated devices. The probe can be placed on any surface, such as metal, glass, plastic etc. The probe can also be useful to measure liquids provided that it is placed inside a water-tight pouch.

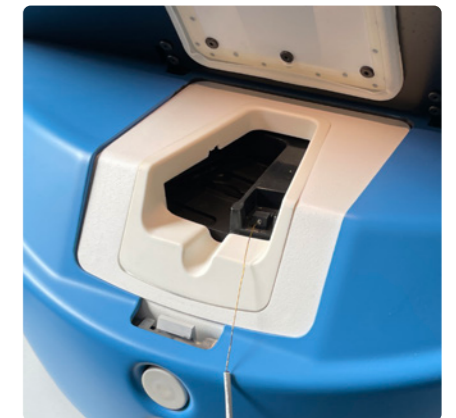
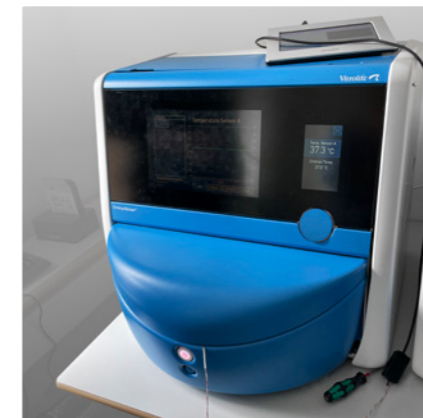

Specifications

Sensor type	Analogue PT-100 temperature sensor (3 wire)
Compatible instruments	NiloChecker 500 and NiloChecker 500 WiFi
Measuring range/accuracy	(-50 to 50) °C / 0,03 °C accuracy possible
Display resolution and update	0,01 °C, one update per second
T90 (min:sec)	0:25
Compliance	ISO/EN61010-1 • RoHS • CE with NiloChecker 500
Operating conditions	(0 to 50) °C / (5 to 95)% RH
Cable length	2 m
Materials	Stainless steel tip, polyamide and Teflon coated connection wires, PVC cable
IP Class	IP50
Calibration	Delivered with factory calibration certificate Accuracy ± 0,1 °C in the range (0 to 50) °C PT120 can be calibrated in accordance with ISO/IEC 17025 Calibration requires adaptor. Part no: 115s001

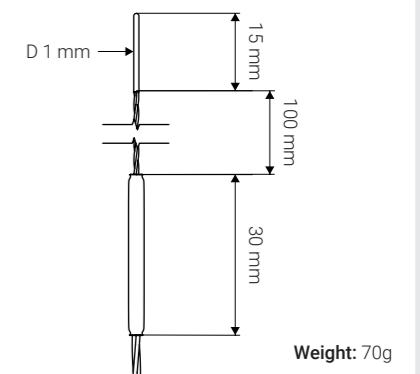

Ordering info

Part no: 120s002 - PT120 Platinum 1 mm Flexible Temperature Probe
Part no: 800s012/800s013 AC - Accredited calibration of 1 temperature sensor in 3 points
Part no: 800s012 - Factory calibration of PT probe in 3 points

Nilotech ApS

Knudstrupvej 14 - DK-4270 Hoeng, Denmark
+45 35 95 32 96 - contact@nilotech.eu - www.nilotech.eu

Document

120d001_06/2026



PT123
2,5 x 100 mm stainless steel PT100

The PT123 represents an important advancement in temperature sensing technology. Its stainless steel encapsulated PT100 sensor ensures high accuracy and stability, making it ideal for precision measurements. The immersible tip allows for precise measurements in test tubes, waterbaths and other containers. Quick response time enables real-time monitoring and control.

Application & Technology

Ideal temperature probe for liquids

The industry standard PT-100 sensor is precise and stable over a wide temperature range. The PT123 measures between -50 °C to 100 °C.

PT123 is particularly useful for controlling liquids in water baths, test tubes, and other fluid containers.

The probe can be inserted into any opening larger than 2,5 mm diameter such as sideports on incubators.



Specifications

Sensor type	Analogue PT-100 temperature sensor (3 wire)
Compatible instruments	NiloChecker 500 and NiloChecker 500 WiFi
Measuring range/accuracy	(-50 to 100) °C / 0,03 °C accuracy possible
Display resolution and update	0,01 °C, one update per second
T90 (min:sec)	0:45
Compliance	ISO/EN61010-1 • RoHS • CE with NiloChecker 500
Operating conditions	(0 to 50) °C / (5 to 95)% RH
Cable length	2 m with option for customisations
Materials	Tip: Stainless steel - Cable: PVC
IP Class	IP50
Calibration	PT123 will be delivered factory calibrated at 0 °C, 37 °C and 49,5 °C Accuracy ± 0,1 °C in the range (0 to 100) °C PT123 can be calibrated in accordance with ISO/IEC 17025 Calibration requires an adaptor. Part no: 115s001

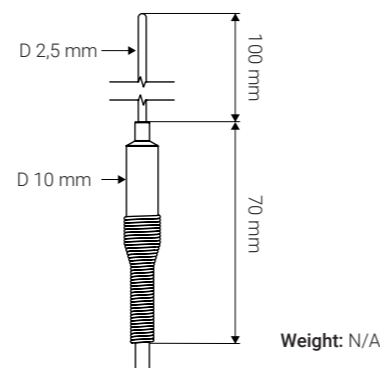

Ordering info

Part no: 120s003 - 2,5 x 100 mm stainless steel PT100
Part no: 115s001 - Single probe calibration adaptor
Part no: 800s012/800s013 AC - Accredited calibration of 1 temperature sensor in 3 points
Part no: 800s012 - Factory calibration of PT probe in 3 points

Nilotech ApS

Knudstrupvej 14 - DK-4270 Hoeng, Denmark
+45 35 95 32 96 - contact@nilotech.eu - www.nilotech.eu

Document

123d001_06/2026

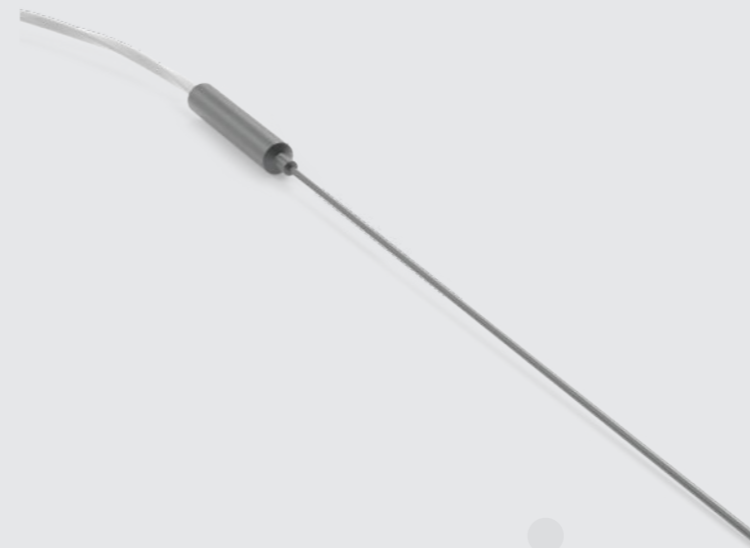

PT125
1,6 x 150 mm stainless steel cryogenic PT100

Maintaining the temperature of cryogenic sample storage is essential to preserve the integrity of cell-based materials used in various research and therapy applications. The PT125 Cryo Temperature Probe is perfect for measuring temperatures inside cryo preservation tanks. With a temperature range from -200°C to +50°C, this probe is suitable for both spot-checking liquid levels and long-term monitoring.

Application & Technology

Specialised cryogenic probe

The PT125 is designed for ease and safety. Its 150mm long tip allows for easy positioning in any open vessel.

The 1.6mm tip minimizes heat transfer through the probe.

The attached Teflon cable enables the entire probe to be immersed in a large dewar for quick level control or long-term monitoring.

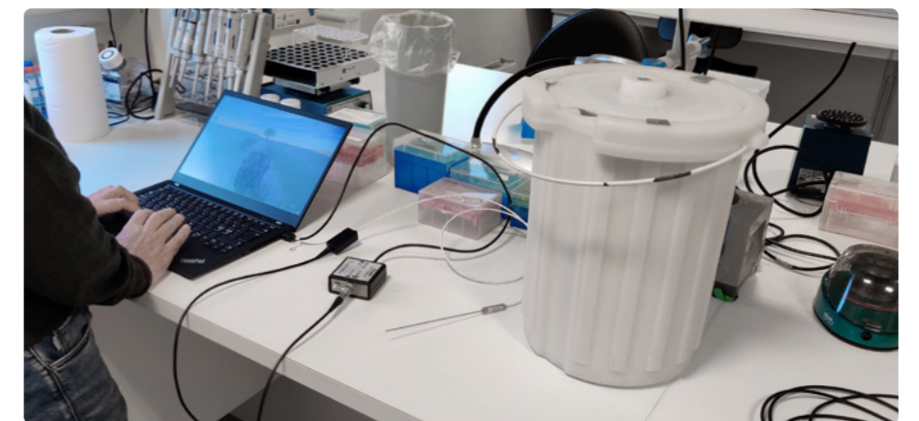

Specifications

Sensor type	Analogue PT-100 temperature sensor (3 wire)
Compatible instruments	NiloChecker 500 and NiloChecker 500 WiFi
Measuring range/accuracy	(-200 to 50) °C / 0,03 °C accuracy possible
Display resolution and update	0,01 °C, one update per second
T90 (min:sec)	0:45
Compliance	ISO/EN61010-1 • RoHS • CE with NiloChecker 500
Room operating conditions	(0 - 50) °C / (5 - 95) % RH
Cable length	2 m with option for customisations
Materials	Tip: Stainless steel - Cable: Teflon and PVC
IP Class	IP50
Calibration	Delivered with factory calibration certificate Accuracy ± 0,1 °C in the range (-200 to 50) °C PT125 can be calibrated in accordance with ISO/IEC 17025 Calibration requires adaptor. Part no: 115s001

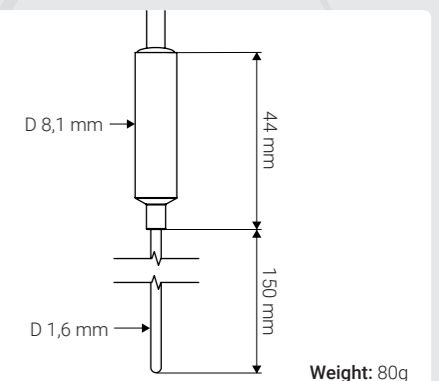

Ordering info

Part no: 120s005 - PT125 Digital Cryo Temperature Probe
Part no: 115s001 - Single probe calibration adaptor
Part no: 800s012/800s013 AC - Accredited calibration of 1 temperature sensor in 3 points
Part no: 800s012 - Factory calibration of PT probe in 3 points

Nilotech ApS

Knudstrupvej 14 - DK-4270 Hoeng, Denmark
+45 35 95 32 96 - contact@nilotech.eu - www.nilotech.eu

Document

125d001_06/2026



DG112
Digital CO₂/O₂ Probe

Measuring gas concentrations within incubators is a complicated task, particularly due to the potential for disturbance to the incubator's environment caused by gas aspiration. The accuracy of measurement is crucial in applications such as cell culture, where maintaining an environment that closely mimics in vivo conditions is essential for optimal cell growth.

Application & Technology

Digital gas probe

This Digital CO₂ and O₂ probe also represent a significant advancement in incubator control technology. Its innovative flat design make it an ideal choice for a variety of laboratory settings, including desktop incubators. The probe enables continuous monitoring of CO₂ and O₂ levels, which is crucial for maintaining the optimal environment for cell cultures and other sensitive biological samples.



Specifications

Sensors	NDIR (CO ₂), Electro-chemical (O ₂)
Compatible instruments	NiloChecker 500 and NiloChecker 500 WiFi
Measuring range	(0 to 30)% O ₂ / (0 to 12)% CO ₂
Accuracy	0,2% O ₂ , 0,1% CO ₂ ± 3% of reading
T90	< 20 sec. (O ₂), < 15 sec. (CO ₂)
Compensation for ambient conditions	Temperature (20 to 40) °C, altitude (700 to 1100) mBar
Display resolution and update	0,1%, one update per sec.
Operating conditions	(5 to 95) % RH (Non condensing)
Cable length	2 m
Compliances	CE with NiloChecker 500 • RoHS
Calibration	Delivered with factory calibration certificate Can be calibrated in accordance with ISO/IEC 17025 Accuracy ± 0,1 °C in the range (0 to 50) °C Calibration requires adaptor. Part no: 115s001

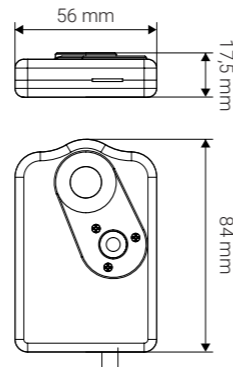

Weight: 130g



Ordering info

Part no: 112s003 - DG112 VFC (Very flat cable for desktop incubators) - Delivered with Factory calibration certificate
Part no: 800s015 - Factory calibration of Nilotech gas probe incl. factory and gas certificates
Part no: 800s015AC - Acc. Gas calibration of DG probe

Nilotech ApS

Knudstrupvej 14 - DK-4270 Hoeng, Denmark
+45 35 95 32 96 - contact@nilotech.eu - www.nilotech.eu

Document
112d001_06/2026



DG122
Digital Flow-Through CO₂/O₂ Probe

The DG122 Digital CO₂/O₂ probe is a state-of-the-art instrument designed for accurate gas analysis. Its cutting-edge technology allows for minimal flow resistance, which is essential for real-time monitoring in a number of applications.

Application & Technology

Dual measurements

The DG122 is a sophisticated gas analyzer designed to measure CO₂ and O₂ levels simultaneously. To ensure accurate readings, it's essential to connect the DG122's input port to a gas sample port on the target device. If the target device has a return port, the DG122's output port should be connected there. For systems with high flow rates, flow restrictors can be utilized to minimize the sample flow, preventing potential measurement errors and ensuring the integrity of the gas analysis.

Note: DG122 does not contain a pump and relies on the flow from the target device. Please refer to DG126 for a probe with pump.

Ease of use

Connect up to 5 pcs DG122 probes simultaneously to each NiloChecker. You can start/stop measurements, monitor progress and store readings for later analysis.

Output data

CO₂ and O₂ in %. The NiloChecker calculates and maps data including minimum, average, and maximum values from any measurement sessions. See NiloChecker specifications for more information.



Specifications

Sensors	NDIR (CO ₂), Electro-chemical (O ₂)
Compatible instruments	NiloChecker 500 and NiloChecker 500 WiFi
Measuring range	(0 to 30)% O ₂ / (0 to 12)% CO ₂
Accuracy	0,2% O ₂ , 0,1% CO ₂ ± 3% of reading
T90	< 20 sec. (O ₂), < 15 sec. (CO ₂)
Compensation for ambient conditions	Temperature (20 - 40) °C, altitude (700 to 1100) mBar
Display resolution and update	0,1%, one update per sec.
Operating conditions	(0 to 40) °C, (5 to 95) % RH (Non condensing)
Cable length	2 m
Tube fittings	6 mm push-in as standard. Other 1/8" fittings optional
Compliances	CE with NiloChecker 500 • RoHS
Calibration	Delivered with factory calibration certificate Can be calibrated in accordance with ISO/IEC 17025 Accuracy ± 0,1 °C in the range (0 - 50) °C Calibration requires adaptor. Part no: 115s001

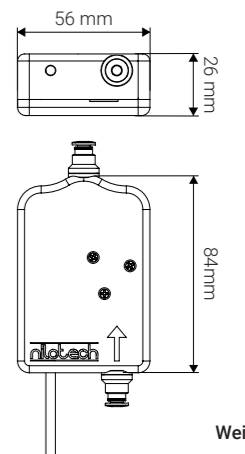

Weight: 230g



Ordering info

Part no: 122s002 - DG122 Digital flow-through CO₂/O₂ probe. - Delivered with factory calibration certificate
Part no: 800s015 - Factory calibration of Nilotech gas probe incl. factory and gas certificates
Part no: 800s015AC - Acc. Gas calibration of DG Probe

Nilotech ApS

Knudstrupvej 14 - DK-4270 Hoeng, Denmark
+45 35 95 32 96 - contact@nilotech.eu - www.nilotech.eu

Document
122d002_06/2026



DG126
Digital CO₂/O₂ Probe with Pump

The DG126 Digital Carbon Dioxide (CO₂) and Oxygen (O₂) probe with pump represents a significant advancement in incubation monitoring technology. Its compact design and broad compatibility make it an ideal choice for managing both box-type and desktop incubators.

Application & Technology

Dual measurements

Connect the flexible tubing to a sample port or use the sample needle to sample from narrow openings. Start the pump from the NiloChecker device, and it measures CO₂ and O₂ simultaneously.

Flexible design

The probe can be placed near or on the target device to minimize tubing length. Short tubing minimizes measurement time and usage of gas.

Ease of use

Connect up to 5 DG126 probes to your NiloChecker simultaneously. With the NiloChecker in your hand, you can start/stop measurements, monitor progress and store readings for later analysis.

Output data

CO₂ and O₂ in %. The NiloChecker calculates and maps data including minimum, average, and maximum values from several measurement sessions. See NiloChecker product sheet for more information about exporting measurement data.



Specifications

Sensors	NDIR (CO ₂), Electro-chemical (O ₂)
Compatible instruments	NiloChecker 500 and NiloChecker 500 WiFi
Measuring range	(0 to 30)% O ₂ / (0 to 12)% CO ₂
Accuracy	0,2% O ₂ , 0,1% CO ₂ ±3% of reading
T90	< 20 sec. (O ₂), < 15 sec. (CO ₂)
Compensation for ambient conditions	Temperature (20 to 40) °C, altitude (700 to 1100) mBar
Pump flow	(100 to 150)mL/min
Display resolution and update	0,1%, one update per sec.
Operating conditions	(0 to 50) °C, (5 to 95)% RH (Non condensing)
Cable length	1 m
Tube fitting	Luer-lock as standard. Other 1/8" fittings optional
Compliances	CE with NiloChecker 500 • RoHS
Calibration	Delivered with factory calibration certificate Can be calibrated in accordance with ISO/IEC 17025 Calibration requires adaptor. Part no: 115s001

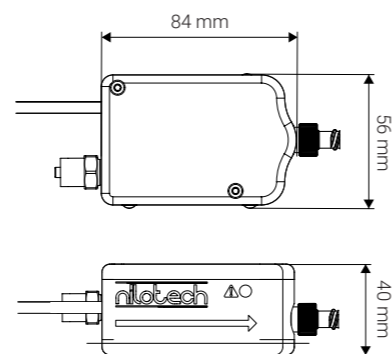

Weight: 280g



Ordering info

Part no: 126s002 - DG126 Digital CO₂/O₂ probe with pump - Delivered with factory calibration certificate
Part no: 800s015 - Factory calibration of Nilotech gas probe incl. factory and gas certificates
Part no: 800s015AC - Acc. Gas calibration of DG Probe

Nilotech ApS

Knudstrupvej 14 - DK-4270 Hoeng, Denmark
+45 35 95 32 96 - contact@nilotech.eu - www.nilotech.eu

Document
126d001_06/2026



DMF119
Digital Mass Flow Probe

The DMF119 - Digital Mass Flow Probe - is for **Pressure** and **Flow** measurement to be used with the NiloChecker.

DMF119 is equipped with a piezoresistive silicon pressure sensor offering a digital output. This technology combines high overpressure and bursts pressure, ensuring both protection and high sensitivity. Flow is measured with a MEMS-sensor, also providing accurate results at high sensitivity.

Application & Technology

Application

DMF119 is intended for service, maintenance, and calibration of a range of equipment and is especially well suited for incubators using pre-mixed gas, and equipment using pneumatics as source of power: OPU-vacuum pumps, Micro-manipulators and other.

Pressure and Flow Measurement

To satisfy different needs for different applications, the DMF119 can be equipped with a variety of nozzles and calibrated within different dynamic ranges. The pressure sensor is extremely accurate ± 0,25% of full-scale reading and has a very long lifetime provided it is used within specified range.

Note: The DMF119 should only be used with non-corrosive, non-ionic gases. DO NOT use the probe for applications involving flow-through of pure oxygen.

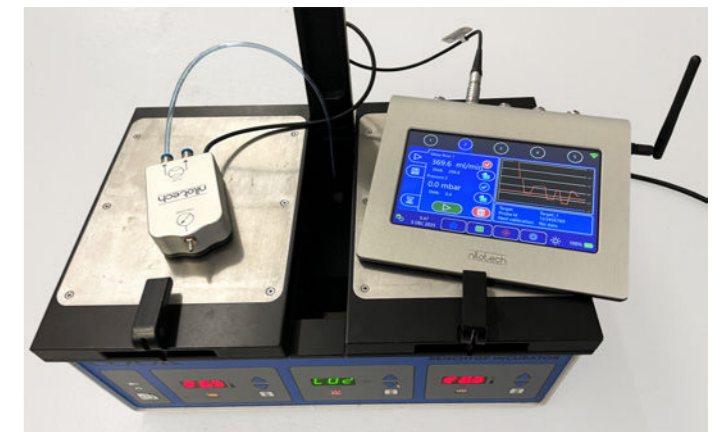

Specifications

Sensor types	MEMS mass flow sensor and piezoresistive silicon pressure sensor
Compatible instruments	NiloChecker 500 and NiloChecker 500 WiFi
Communication	Serial Digital
Data in probe	Calibration offset, Calibration day and interval, Probe identification, Sensor data, Sensor range, Sensor accuracy
Measuring range	Flow: (0 to 1000)mL/min, Pressure: Standard is (-800 to 1000) mBar or (0 to 2000) mBar. Specify at ordering or inquire for other range.
Accuracy	Flow: ± 1mL/min (± 0,65%FS), Pressure: ± 3 mBar (± 0,25%FS)
T90 (min:sec)	<5 sec
Display resolution and update	0,1mL/min flow and 0,1 mBar pressure, one update per second
Operating conditions	(0 to 50) °C, (5 to 95) % RH (Non condensing)
Cable length/materials	1 m
Tube fittings	Flow: 4 mm push in, Pressure: Hose nipple for 2-3 mm soft hose
Compliance	CE with NiloChecker, RoHS, REACH
Calibration	Delivered with factory calibration certificate The probe has a zero-calibration function Can be calibrated in accordance with ISO/IEC 17025 Calibration requires adaptor. Part no: 115s001

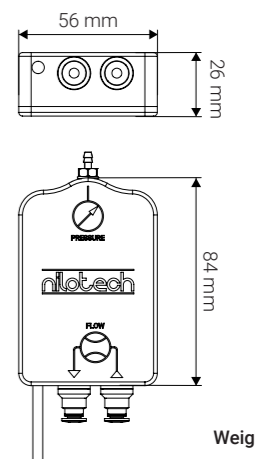

Weight: 230g



Ordering info

Part no: 119s003 - DMF119 Digital Mass Flow Probe - Delivered with factory calibration

Nilotech ApS

Knudstrupvej 14 - DK-4270 Hoeng, Denmark
+45 35 95 32 96 - contact@nilotech.eu - www.nilotech.eu

Document
119d003_06/2026



DLV119
Digital Low Velocity Air Flow Probe

Correct laminar flow in IVF workstations is crucial to avoid contaminating cells and ensuring operator safety. The DLV119 can be used to control filters and flow according to manufacturer's recommendations and international standards such as EN 12469 in:

- Biological Safety Cabinets
- Chemical Fume Hoods
- Laminar Flow Hoods
- Clean Benches
- HEPA & Filter Boxes
- And other

DLV119 is a versatile and rugged, high-performance air velocity probe for low flow.

Application & Technology

Functions and Technology

DLV119 is suitable for demanding applications, including those in corrosive or alkaline environments. With its robust, splash-proof design, the DLV119 is designed to support a wide range of product and process control air flow applications.

The NiloChecker software supports calculation of airflow in accordance with international standards as well as providing for easy reporting.

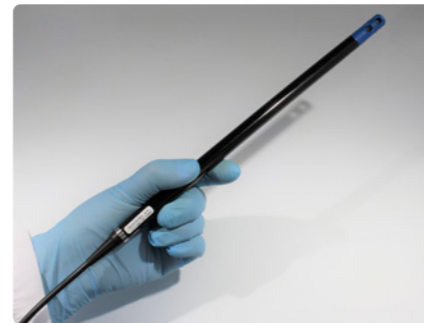

Specifications

Sensors	Hot wire anemometer. Temperature compensated
Compatible instruments	NiloChecker 500 and NiloChecker 500 WiFi
Measuring range	Flow: (0,15 to 1,5) m/s. Temperature: (0 to 60) °C
Accuracy	Flow: ±1% of reading + 0,05 m/s. Temperature: ±1 °C
Response time	400 ms
Compensation for ambient conditions	Temperature (0-60 °C)
Display resolution and update	0,01 m/s, 0,01 °C, one update per sec.
Operating conditions	5-95% RH (Non condensing)
Cable length	2 m
Materials	Cable: PVC coated Housing: Polycarbonate (PC), UL94-V0 (head) UL94-HB (housing), Aluminium (Cable ring)
Compliances	CE with NiloChecker 500 • RoHS
Calibration	Delivered with factory calibration certificate Can be calibrated in accordance with ISO/IEC 17025 Calibration requires adaptor. Part no: 115s001

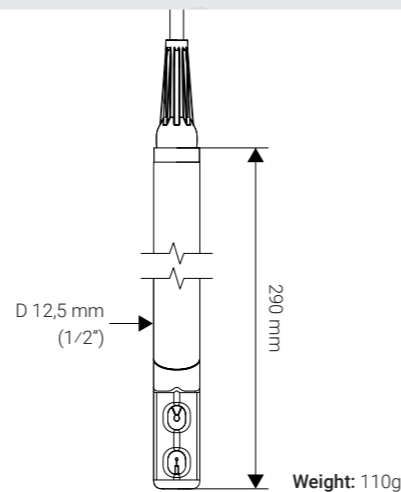

Ordering info

Part no: 119s001 - DLV119 Digital Air Velocity Probe - Delivered with factory calibration
Part no. 800s014AC - Acc. Calibration of DLV119 at 3 velocities

Nilotech ApS

Knudstrupvej 14 - DK-4270 Hoeng, Denmark
+45 35 95 32 96 - contact@nilotech.eu - www.nilotech.eu

Document

119d001_06/2026



DH140
Digital Humidity Probe

The DH140 - Humidity and Temperature Probe is a robust and cost-effective humidity transmitter with high accuracy and good stability. DH140 is suitable for incubators, laboratories, greenhouses and fermentation devices.

Application & Technology

Robust design

The stainless steel body of DH140 is classified as IP65, making it ideal for rough conditions. DH140 has high chemical tolerance thanks to the digital sensor.

DH140 is connected via a thin flexible cable so it can be positioned inside box- or desk-type incubators without affecting the environment. The magnetic probe holder 140sp002 makes it convenient to install the sensor in the environment. A strong magnet stays firmly attached to steel structures. Alternatively, Ø3.5 mm holes can be used for screw fastening.



Specifications

Sensor type	Capacitive type
Compatible instruments	NiloChecker 500 and NiloChecker 500 WiFi
Measuring range /accuracy	(0 to 80)% RH, ±1.5%, (0 to 60) °C (80 to 100)% RH, ±2%, (0 to 80) °C (20 to 50) °C, ±0.1 °C
Stability	±0,25% RH over 1 year
Display resolution and update	0,1% RH, one update per sec.
T90 (min:sec)	0:26s
Compliance	ISO/EN61010-1 • EN 61326-1 • RoHS • CE with NiloChecker 500
Operating conditions	(0 to 50) °C / (5 to 95)% RH
Cable length/materials	0,5 m TPE (flat part), 1,2 m PVC (round part) and ABS (junction box)
Sensor Materials	Stainless steel (housing and grid)
IP Class	IP65
Calibration	Delivered with factory calibration certificate Accuracy ±1,5% RH in the range (0 to 80)% RH, (0 to 60) °C DH140 can be calibrated in accordance with ISO/IEC 17025 Calibration requires an adaptor. Part no: 115s001

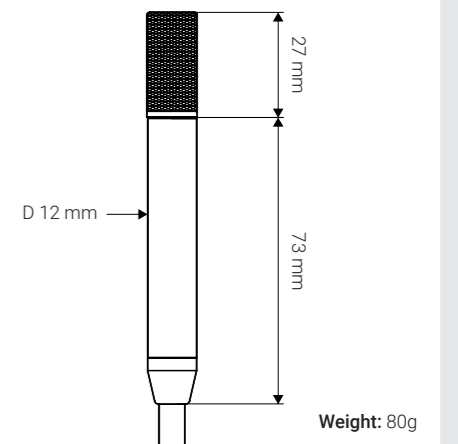

Ordering info

Part no: 140s001 - DH140 Digital Humidity Probe
Part no: 140sp002 - Magnetic Probe Holder for DH140
Part no: 800s016 - Factory R.H. calibration of DH140

Nilotech ApS

Knudstrupvej 14 - DK-4270 Hoeng, Denmark
+45 35 95 32 96 - contact@nilotech.eu - www.nilotech.eu

Document

140d001_06/2026

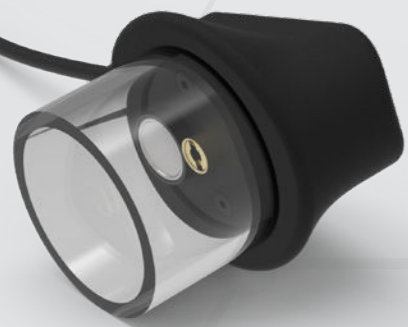

DLT145
Digital Laser Tachometer Probe

Centrifuges deliver preparative separation technology, that decides purity and concentration of crucial components used in the laboratory. Keeping your centrifuges in good condition is therefore very important.

Application & Technology

The DLT145 - Digital Laser Tachometer Probe is designed for use with the NiloChecker to measure revolutions per minute (RPM) typically in centrifuges used in the biomedical, chemical, environmental or other analytical laboratories.

The probe utilises state of the art optical detection for measuring speed, using our proprietary hard- and firmware and has the same overall design as all other NiloProbes.

- Head Ø (inner/outer) = Centrifuge (size) range inner 34 mm outer 40 mm

- Receiver: optodiode with front lens to ensure high sensitivity and resistance against external disturbance

- Delivered with reflective tape to mount on one of the centrifuge arms to give well defined reflection

- Housing: softly rounded housing for excellent grip

Compatibility and ease of use makes the DLT145 attractive to the service engineer focusing on above mentioned laboratories.



Specifications

Sensor type	Optodiode with front lens
Light emission	Red Laser, wavelength 650 nm
Compatible instruments	NiloChecker 500 and NiloChecker 500 WiFi
Measuring range	Distance up to 100 cm (0 to 40)" Rotations: (10 to 12.000) RPM
Display resolution and update	1 RPM, one update per sec.
Compliance	CE with NiloChecker 500 • RoHs
Operating conditions	(0 to 40) °C / (5 to 85)% RH
Cable length	0,5 m
Materials	Cable: PVC coated Housing: Nylon, Polycarbonate (PC)
IP Class	IP50
Calibration	Delivered with traceable factory calibration certificate Can be calibrated in accordance with ISO/IEC 17025 Calibration requires adaptor. Part no: 115s001

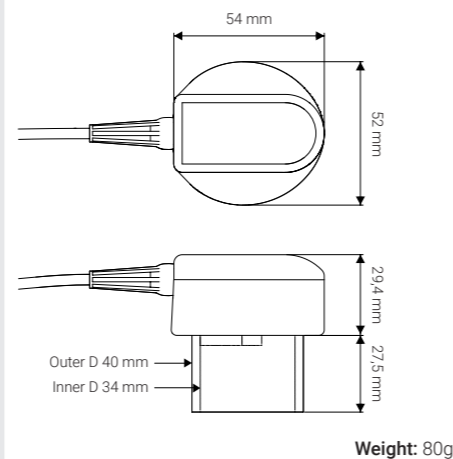

Ordering info Part no: 145s001 - DLT145 Digital Laser Tachometer Probe - Delivered with factory calibration

Nilotech ApS

Knudstrupvej 14 - DK-4270 Hoeng, Denmark
+45 35 95 32 96 - contact@nilotech.eu - www.nilotech.eu

Document
145d001_06/2026



NiloBlock

A heating block concept for oocyte retrieval
An insulated heating block which brings optimal temperature stability to test tubes. The design allows visual inspection of tube content with minimal heat loss. NiloBlock can be used with standard heating surfaces and compatible block heaters.

Application & Technology

The important insulation
Block and tubes are thermally insulated from the outside by a thin layer of air between block and cover. The insulation ensures a uniform temperature throughout the tubes.

Smart cover
The transparent cover allows observation of the tube content, which is important during Oocyte retrieval. The cover easily snaps on and off for cleaning.

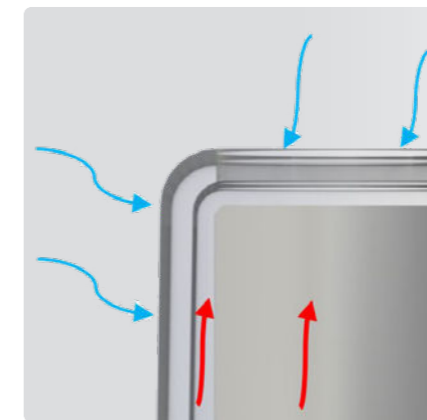

Specifications

Materials	Block: Anodized aluminum Cover: Polycarbonate
Country of origin	Denmark
Cleaning	Block: Handwash and/or autoclave Cover: Handwash or machinewash (maximum 70 °C)

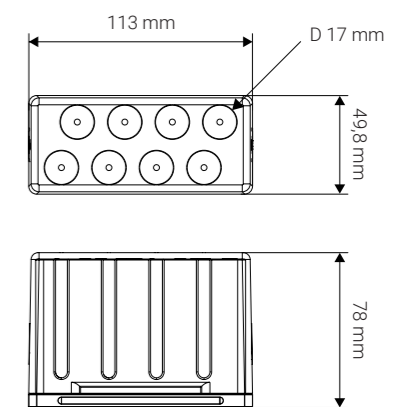

Ordering info Part no: 110s002 - NiloBlock

Nilotech ApS

Knudstrupvej 14 - DK-4270 Hoeng, Denmark
+45 35 95 32 96 - contact@nilotech.eu - www.nilotech.eu

Document
110d001_06/2026



Accessories

Accessories for our product range.



Accessories

Accessories for our product range.



Calibration adaptor

Adaptor to check and adjust any NiloChecker probe

Ordering info
Part no: 115s001



Water trap for DG126

Water trap with luer-lock fittings

Ordering info
Part no: 126sp002



Calibration cap for DG112

Silicone cap for callibrating the DG112 - CO₂ /O₂ probe

Ordering info
Part no: 112s002

Fermacidal 2 wipes, 70 pcs.

Ready-to-use alcohol-free disinfectant for surfaces and instruments

Smell-removal and neutralisation of odourcausing bacteria, does not stain, is blood-dissolving and has very good material compatibility with metals, rubber, plastic, wood, etc. The Fermacidal wipes are also suitable for disinfection of CO₂ incubators and ultrasonic probes.

Microbiological efficacy:

- Bactericidal, e.g.: *Salmonella*, *Mycobacterium tuberculosis*
- Fungicidal, e.g.: *Trichophyton mentagrophytes*
- Selective virucidal, e.g.: *Hepatitis B/C*, *HIV*, *Rotavirus*, *Influenza A*, *Corona viruses*

Ordering info
Part no: 130s002



Extension cable

3 m. extension cable for NiloChecker probes

Ordering info
Part no: 112s005



NiloCase

Mobile hard case for NiloChecker and sensors

Ordering info
Part no: 111s020





Notes

A space for your thoughts, ideas and notes.

Lined writing area for notes.



Notes

A space for your thoughts, ideas and notes.

Lined writing area for notes.



nilotech

Nilotech ApS

Knudstrupvej 14 - DK-4270 Hoeng, Denmark
+45 35 95 32 96 - contact@nilotech.eu - www.nilotech.eu